

MODEL PAC 7-10
REGULATED DC POWER SUPPLY
OPERATION MANUAL

7/11/76
Bundling Dept

KIKUSUI ELECTRONICS CORP.

Power Requirements of this Product

Power requirements of this product have been changed and the relevant sections of the Operation Manual should be revised accordingly.

(Revision should be applied to items indicated by a check mark)

Input voltage

The input voltage of this product is _____ VAC,
and the voltage range is _____ to _____ VAC. Use the product within this range only.

Input fuse

The rating of this product's input fuse is _____ A, _____ VAC, and _____.

WARNING

- To avoid electrical shock, always disconnect the AC power cable or turn off the switch on the switchboard before attempting to check or replace the fuse.
- Use a fuse element having a shape, rating, and characteristics suitable for this product. The use of a fuse with a different rating or one that short circuits the fuse holder may result in fire, electric shock, or irreparable damage.

AC power cable

The product is provided with AC power cables described below. If the cable has no power plug, attach a power plug or crimp-style terminals to the cable in accordance with the wire colors specified in the drawing.

WARNING

- The attachment of a power plug or crimp-style terminals must be carried out by qualified personnel.

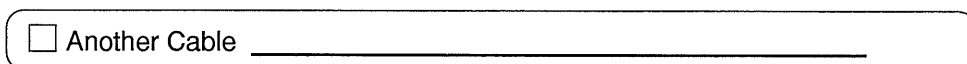
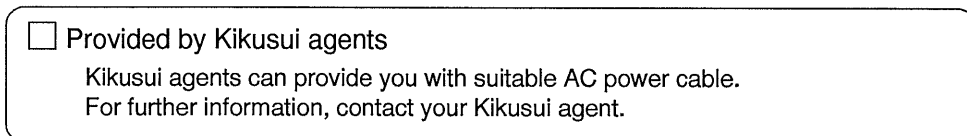
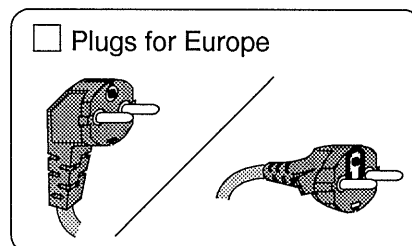
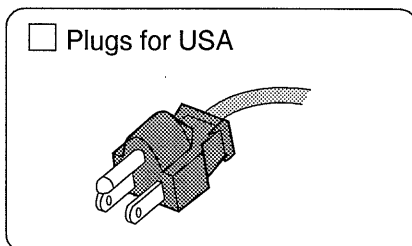
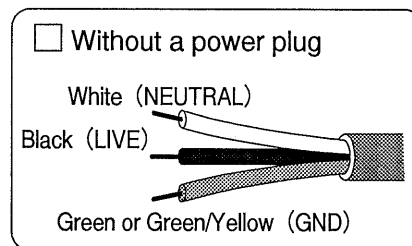
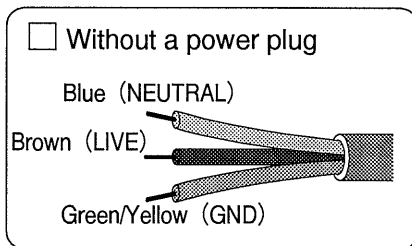

C O N T E N T S

	Page
1. INTRODUCTION	1
2. SPECIFICATIONS	2
3. OPERATION (1)	4
3.1 Explanation of panel	4
3.2 Explanation of rear panel	4
3.3 Precaution	5
3.4 How to use sampling terminals	6
4. OPERATION (2)	8
4.1 Single operation	8
4.2 Series operation	9
4.3 Parallel operation	10
4.4 One-control parallel operation	12
4.5 Remote control	13
5. MAINTENANCE	15
* CIRCUIT DIAGRAM	

1. INTRODUCTION

Kikusui Electronics' Model PAC7-10 is an IC used and all-silicon-transistorized, highly reliable, variable regulated DC power supply which has excellent regulation, a low temperature coefficient and quick transient response. It is a universal type usable for either a digital or analog circuit.

The output voltage is adjustable finely and automatically over a range of zero to 7V with a 10-turn type variable resistor.

The maximum output current is 10A. Model PAC7-10 can be used as a constant current power supply over a range of 0.5 to 10A.

Use of a new circuit technique (utility model patent pending) permits the constant current characteristics to be improved largely, as compared with the other type.

Model PAC7-10 is a constant voltage-current automatic crossover type in which the constant output voltage performance and constant current performance are changed over automatically according to load variation.

Two LED mounted on the front panel indicate the respective operation modes alternately (constant voltage or constant current).

Model PAC7-10 is not only used in single operation but in series, parallel or one-control parallel operation by which the voltage or current can be expanded.

Use of an external resistor also permits the output voltage to be remote-controlled.

2. SPECIFICATIONS

AC input	_____ V AC+10%, 50/60Hz
Full load	Approximately 230VA
Dimensions	Case 210W × 140H × 410D mm*
Maximum	215W × 165H × 453D mm
Weight	Approximately 11.5 kg
Ambient temperature	0 - 40°C
Accessories supplied	Short bar 1
	Fuse 10A..... 2
	Operation manual 1
Output	
Terminals	On the front panel color coded, aligned horizontally, Spaced 19 mm equally (-, GND, +); the terminal board on the rear panel (-sampling, -, GND, +sampling, +); a built-in switch for output.
Polarity	Positive or negative
Floating voltage	±150V maximum
Constant voltage characteristics;	
Voltage	0 - 7V continuously variable with 10-turn variable resistor
Current	10A
Ripple and Noise (5 Hz - 1 MHz)	500µV rms
Voltage regulation	
Line regulation	0.005% + 1mV against ±10% variation of line voltage
Load regulation	0.005% + 1mV against 0 - 100% variation of load current

Transient response time	Typical 100 μ s
Temperature coefficient	Typical 100PPM/ $^{\circ}$ C
Constant current characteristics;	
Voltage	0 - 7V continuously variable with 10-turn variable resistor
Current	0.5 - 10A
Ripple and Noise (5 Hz - 1 MHz)	1mA rms
Current regulation	
Line regulation	1mA against \pm 10% variation of line voltage
Load regulation	3mA against 0 - 100% variation of output voltage

Operation

Series connection.

Parallel connection.

One-control parallel operation.

Output voltage remote control.

Operation mode indication

indication	Constant voltage	C.V
by light emission diode	Constant current	C.C

Voltmeter	DC 8V	accuracy 2.5% of full scale
Ammeter	DC 12A	accuracy 2.5% of full scale

- * Two PAC7-10s can be mounted side by side on 19" or 500 mm standard rack with the rack mount frame.
- * Over voltage protector Model OVP7-50 can be mounted as option.

A 79.2.15 Form 5-turn to 10-turn 39A14

3. OPERATION (1)

3.1 Explanation of panel (See Fig. 1)

- | | |
|--------------------------------------|-------------------------------------------------------------------------------------------------------|
| (1) POWER switch | ON/OFF switch for the input power. Throw it upwards, and the power is on. |
| (2) Pilot lamp | Lights when the power is on. |
| (3) Constant voltage indicating lamp | Lights when Model PAC7-10 in the constant voltage mode. |
| (4) Constant current indicating lamp | Lights when Model PAC7-10 is in the constant current mode. |
| (5) OUTPUT | ON/OFF switch for the output. It can disconnect the output from the load. |
| (6) VOLTAGE | Knob for setting the output voltage. Clockwise rotation increases the output voltage. |
| (7) CURRENT | Knob for setting the output current. Clockwise rotation increases the output current. |
| (8) Voltmeter | Reads the output voltage. DC 8V |
| (9) Ammeter | Reads the output current. DC 12A |
| (10) Output terminal | Spaced 19 mm equally and aligned in the following order; from the left, -(white), GND(black), +(red). |

3.2 Explanation of rear panel (See Fig. 2.)

- | | |
|------------------|-------------------------------------------------------------------------------------------------------------------------------------------------------|
| (11) Input fuse | Inserted in the primary of the power transformer to avoid possible subsequent faults trouble.
Slow blow type 4A. |
| (12) Output fuse | Inserted on the output side to prevent surge current trouble from flowing through the equipment connected, and from causing resultant damage, 10AFuse |

(13) Rear terminal board

Output terminals, sampling terminals, remote control terminals and one-control parallel operation terminals are provided on it.

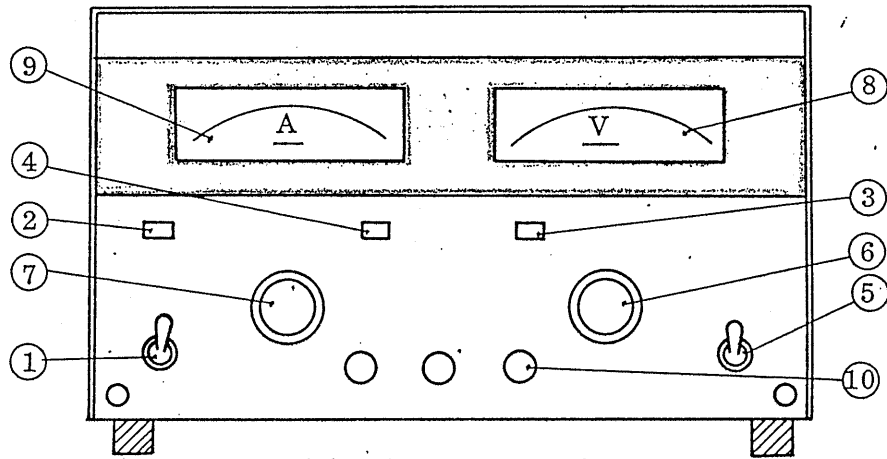

Fig. 1 Front Panel

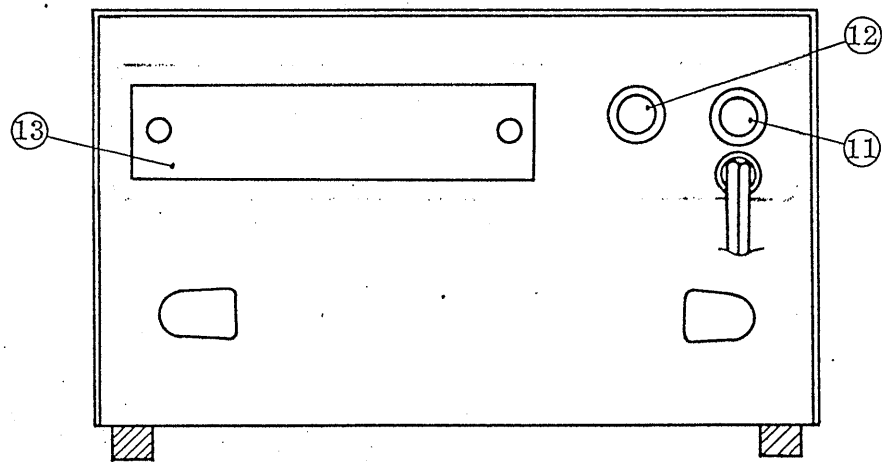

Fig. 2 Rear Panel

3.3 Precaution

AC input

AC input for Model PAC7-10 should be within a range of ___ V AC \pm 10%, 48 - 62 Hz.

Installation

Avoid using Model PAC7-10 at a place exposed to heat; where the ambient temperature exceeds a range of zero 40°C; that is humid or dusty; where it won't be level.

During operation, don't lay Model PAC7-10 on its side nor put anything on it. Otherwise, a fault may be caused by reduction of its radiation effect.

3.4 How to use sampling terminals

When Model PAC7-10 is positioned far from the load, a long lead connecting the output terminals and the load causes load regulation to be deteriorated because of voltage drop due to lead resistance.

The sampling terminals on the rear panel serve to solve this trouble.

For the connection diagram, see Fig. 3.

1. Disconnect the jumpers between terminals 1 and 2, 4 and 5 on the rear panel.
2. Connect the output terminals on the rear or front panel with the load. Connect the sampling terminals and the nearest load terminals with other leads.

Match the polarity of the sampling terminals to that of the output terminals.

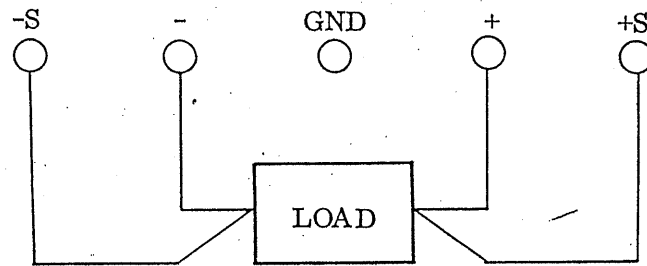

Fig. 3

Note 1 Deterioration of load regulation is calculated by the following formula;

$$V_d = I_o \times R(m\Omega)$$

where

$I_o(A)$ = Load current, $R(m\Omega)$ = lead resistance

V_d = Voltage drop

Note 2 Use two-conductor shielded wire for sampling to avoid induction causing ripple from outside.

Check the sampling leads for proper polarity.

Note 3 Be careful since the lead connected to the load affects the preset constant current value due to its resistance.

4. OPERATION (2)

4.1 Single operation

Constant voltage performance

1. Connect the power cord. Throw the power switch upwards, and Model PAC7-10 is energized immediately, lighting the pilot lamp simultaneously.
2. Turn CURRENT knob fully clockwise. Turn VOLTAGE knob until the desired voltage is obtained. (Clockwise rotation increases the output voltage.)
3. Throw the output switch downwards. Connect the output terminals and the load.
4. Throw the power switch upwards, and the output is connected to the load.

Note: When requiring limiting the load current to a certain value, throw the power switch upwards after the procedure described in Paragraph (2) above. Short the output terminals. Set "CURRENT" knob to the desired current value.

Constant current performance

1. The same as Paragraph (1) in "Constant voltage performance" above.
2. Turn "VOLTAGE" knob clockwise until stop.
(This implies the maximum output voltage.)
3. Throw the output switch upwards. Short the output terminals. Turn "CURRENT" knob until the desired current value is obtained. (Clockwise rotation increases the output current.)
4. The same as Paragraph 3 in "Constant voltage performance" above.
5. The same as Paragraph 4 in "Constant voltage performance" above.

Note 1 Model PAC7-10 is a constant voltage-current automatic crossover type. When the load current is large, the constant current mode is changed over to the constant voltage mode at a specific voltage. Thus, when requiring limiting the output voltage to a certain value, preset the output voltage to the desired value.

Note 2 The constant voltage or constant current mode is indicated by the respective lamps on the front panel alternately.

Constant current mode LED C.C
 Constant voltage mode LED C.V
 (LED : Light Emission Diode)

Note 3 For use of the sampling terminals, see Note 3 in Chapter 3.4 "How to use sampling terminals".

4.2 Series operation

A higher output voltage than 7V can be obtained by connecting two Model PAC7-10s in series.

Note 1 Be careful not to ground the positive terminal of one Model PAC when grounding the negative terminal of the other in Fig. 4.

Note 2 The voltage at each output terminal should not exceed the floating voltage.

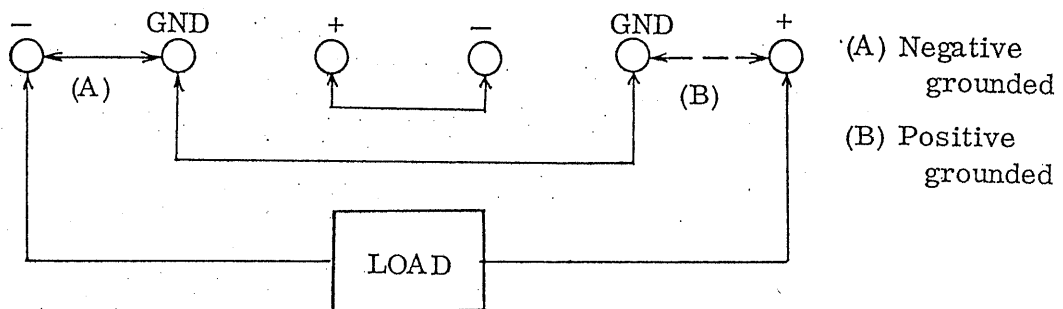

Fig. 4 Series operation connection diagram

When two Model PAC7-10s connected in series are overloaded, one Model PAC7-10, which has been changed over to the constant current mode first, would be supplied with the output voltage of the other inversely. This would damage a series transistor of the former. To avoid this trouble, a diode is connected between the output terminals of each Model PAC7-10 as shown in Fig. 5.

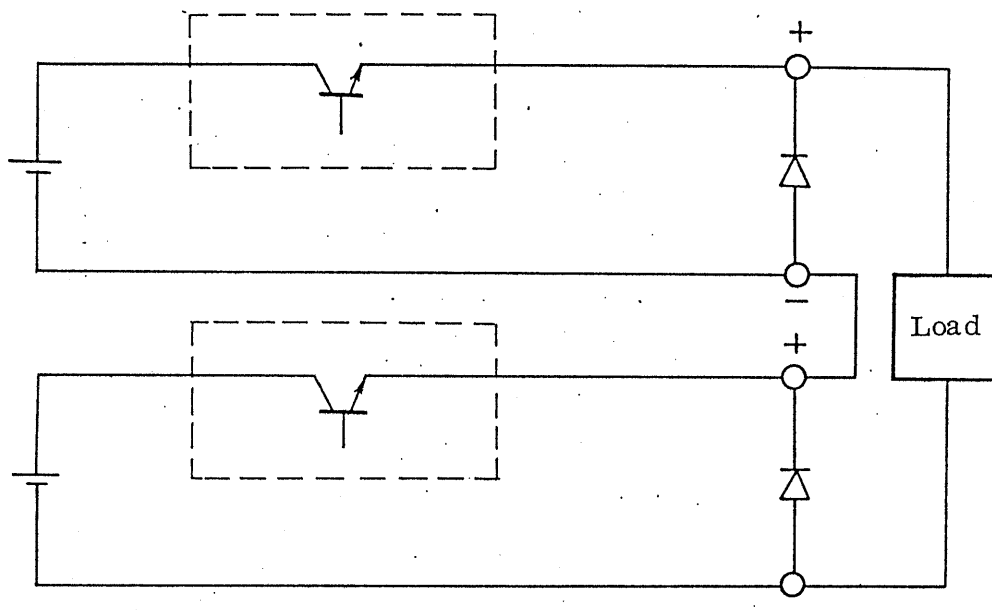

Fig. 5

4.3 Parallel operation

When a larger current than 10A is required, connect the output terminals of two Model PAC7-10s in parallel.

1. Set the output voltages of the two Model PAC7-10s in parallel operation at values as close to each other as possible, since a setting difference between the two would cause load fluctuation.

2. Turn "CURRENT" knobs fully clockwise.
3. Connect the output terminals of two Model PAC7-10s to the load so that their polarity matches.

The grounding polarity of both should also match.

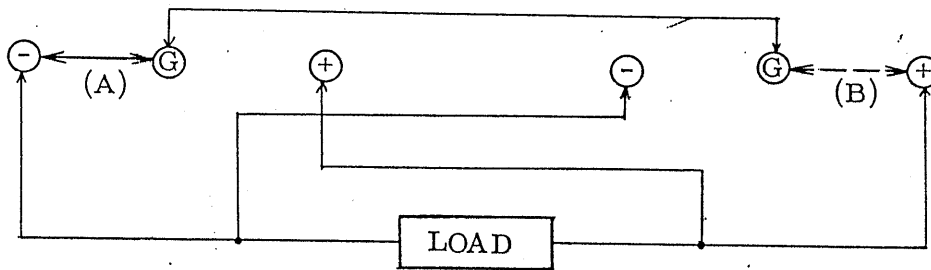

(A):Negative grounded (B):Positive grounded
Fig. 6 Parallel operation connection diagram

Voltage-current characteristics in parallel operation.

As the voltage-current characteristics in parallel operation in Fig. 7 show the output voltage in parallel operation remains constant until one Model PAC7-10 with a higher output voltage is overloaded. When one Model PAC7-10 is changed over to the constant current mode, the output voltage decreases until it reaches the value preset by the other Model PAC7-10, whose output terminals are changed over from an inverse voltage condition to a normal one, causing the constant voltage mode. Thus, load fluctuation causes the output voltage to fluctuate by the preset output voltage difference ΔV between the two units, and ripple characteristics are reduced.

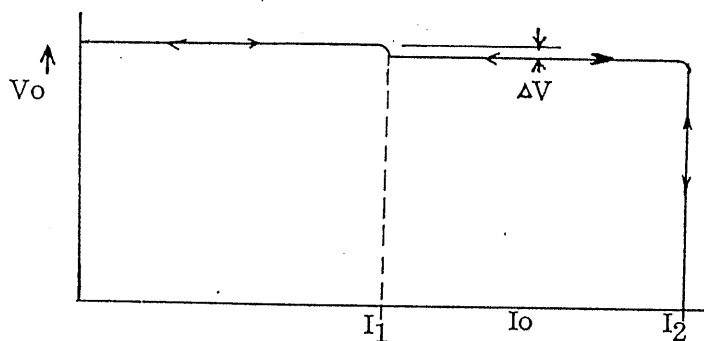

Fig. 7 Characteristics diagram

4.4 One-control parallel operation

When a larger current than 10A is required, one-control parallel operation of two Model PAC7-10s is preferable since the characteristics are improved largely, as compared with those in parallel operation.

In one-control parallel operation, one of the Model PAC7-10s operates as the master unit, by which the output voltage is adjusted, and the other as the slave whose output voltage is controlled by the master unit.

1. Connect the terminals on the rear panel of the master or slave and the load as shown in Fig. 8.
2. Pick up the output at the output terminals on the rear panel of the master. When turning on the power or output switches of the master and slave, start with the master. When turning them off, start with the slave.

Note 1 Picking up the output on the output on the front panel of the master causes load regulation to be deteriorated somewhat, and current unbalance occurs between the master and slave.

Note 2 To prevent load regulation from deteriorating, use the sampling terminals.

Note 3 Turn "VOLTAGE, CURRENT" knobs of the slave fully clockwise.

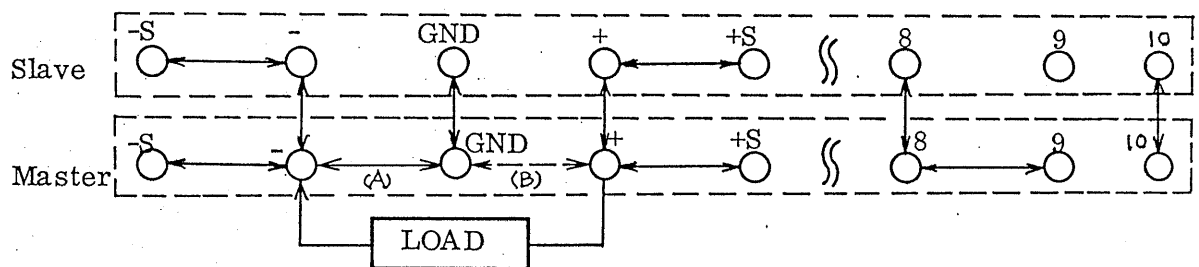

(A): Negative grounded (B): Positive grounded

Fig. 8 One-control parallel operation master, slave, load

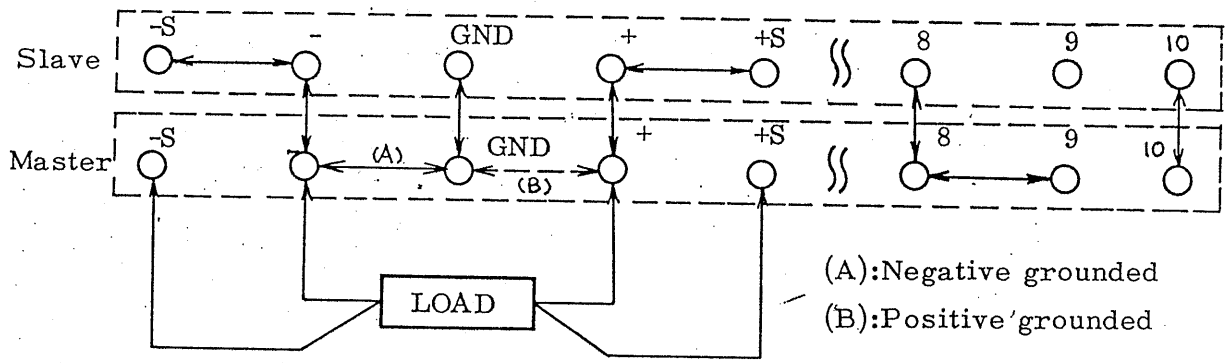

Fig. 9 Using sampling terminal in one-control parallel operation

4.5 Remote control

When remote control of the output voltage setting or improvement of its resolution in Model PAC7-10 is required, use the terminals for remote control.

Turn off the power switch. Connect the terminals on the rear panel, the load and the external variable resistor as shown in Fig. 10.

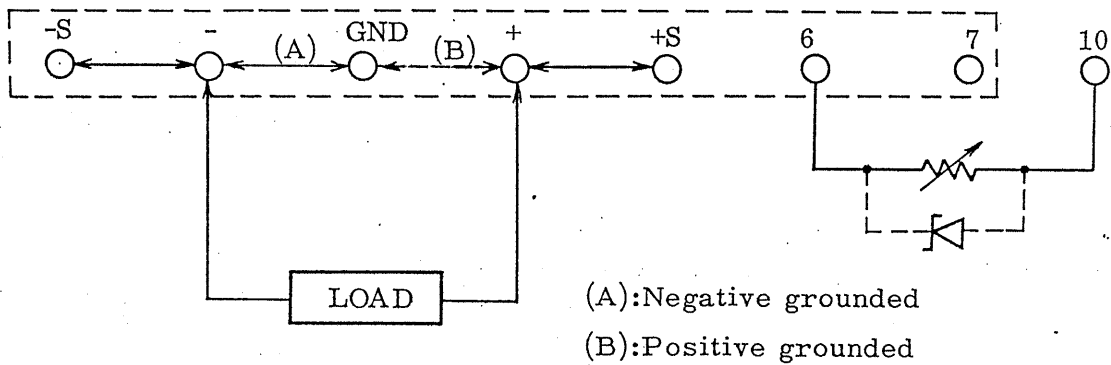

Fig. 10 Remote control connection diagram

Turn ON the power switch, and the output voltage can be adjusted with the variable resistor in steps of approx. $0.7 \text{ V/K}\Omega$. When a voltage higher than a certain value is not desired, connect a zener diode (with a small leakage current) in parallel with the variable resistor.

A wire-wound variable resistor or a metal film variable resistor whose temperature coefficient is small, rated wattage is more than 0.5W, and whose resistance value is not more than 10 K Ω is recommended. Use two-conductor shielded wire for connecting the variable resistor and Model PAC7-10.

5. MAINTENANCE

5.1 Adjustment of maximum output voltage

- 1) Turn VOLTAGE knob to clockwise 10 turns.
- 2) Turn on OUTPUT switch, and connect a voltmeter having an accuracy of over 0.5% to the output terminal.
- 3) Adjust semi-fixed resistor RV_2 on PCB A-001B until the output voltage becomes 7.2V.

5.2 Adjustment of maximum output current

- 1) Turn VOLTAGE knob fully counter clockwise.
- 2) Turn CURRENT knob fully clockwise.
- 3) Connect an ammeter having an accuracy of over 0.5% to the output terminals, and slowly increases the voltage by turning VOLTAGE knob.
- 4) Turn semi-fixed resistor RV_1 on PCB A-001B until the output current becomes 10.2A.

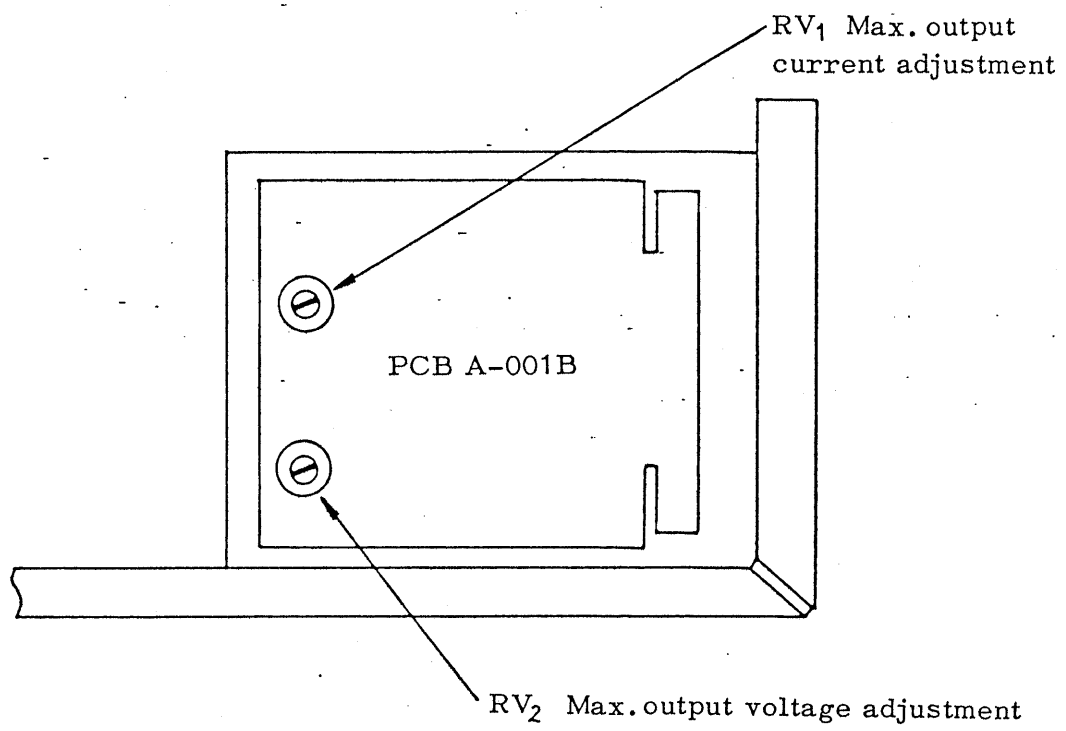

Fig. 5-1 Right side PCB A-001B